



Techni
ENGINEERING SOLUTIONS

VOLKSWAGEN CRAFTER

CR30 / CR35 / CR39 / CR50

CODE / CODICE: 0500.7602

**COMPRESSOR / COMPRESSEUR / KOMPRESSOR
/ COMPRESSORE / COMPRESOR :**

SELTEC: SP13 / 15 / 16

QUE: QP13 /15/ 16

FITTING INSTRUCTIONS

EINBAUANLEITUNGEN

INSTRUCTIONS POUR LE MONTAGE

ISTRUZIONI DI MONTAGGIO

INSTRUCCIONES DE MONTAJE

Contents

ENGLISH	4
Parts View.....	4
Parts List	5
Recommended Compressors	6
Standard Fastener Torque Values	6
Vehicle Details	7
Kit Details	7
Forward	7
Pre-Installation	8
Crankshaft Pulley Installation.....	8
Mount Bracket Installation	10
Compressor Installation	10
Tensioner Installation	11
Drive Belt	11
Post Installation.....	12

PARTS VIEW / VUE ÉCLATÉE / TEILEANSICHT / VISTA PARTA / IMÁGENES DE LAS PIEZAS

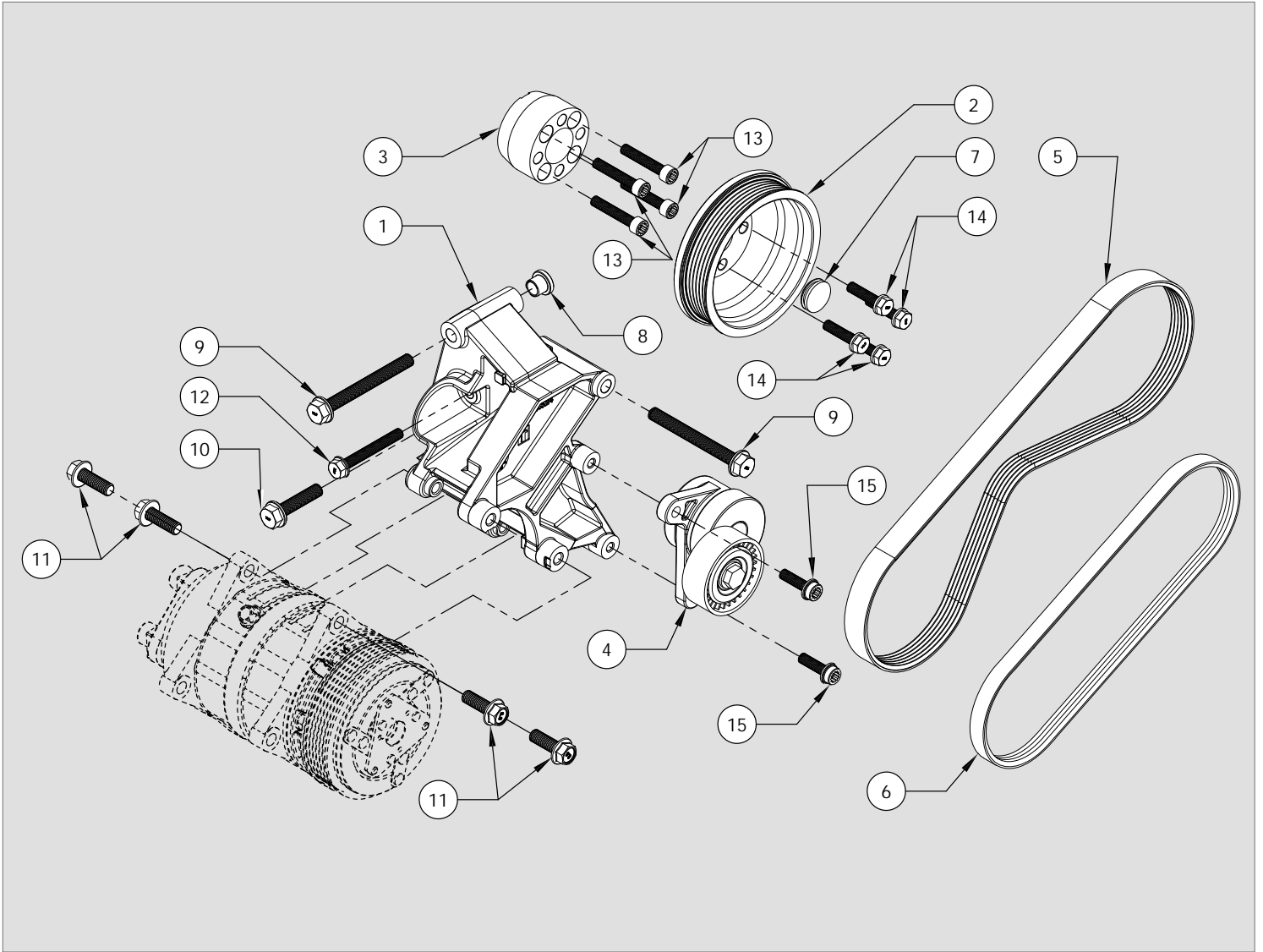

PARTS LIST / NOMENCLATURE / TEILELISTE / ELENCO DELLE PARTI / LISTA DE PIEZAS

ITEM	CODE / CODICE / KODE / CODIGO	DESCRIPTION / DESCRIZIONE / BESCHREIBUNG / DESCRIPCION	QTY.	COMMENTS
1	0441.5243	Compressor Mount Bracket	1	-
2	1701.5401	Auxiliary Crankshaft Pulley Dia 149	1	-
3	1701.5152	Auxiliary Crankshaft Pulley Spacer	1	-
4	1705.5071	Automatic Tensioner	1	-
5	0820.7231	Belt - Poly Groove 6PK 1010	1	-
6	0820.5231	Belt - Poly Groove 4PK 711 Elast	1	-
7	2761.5001	Auxiliary Pulley Grommet	1	-
8	2803.5651	Spacer - 20 (14) OD x 11.0 ID x 4H	1	-
9	2705.5181	Hex Flange Bolt - M10 x 95 : 1.50 - 10.9	2	-
10	2705.0401	Hex Flange Bolt - M10 x 45 : 1.50 - 10.9	1	-
11	2705.5311	Hex Flange Bolt - M10 x 30 : 1.50 - 8.8	4	-
12	2704.5461	Hex Flange Bolt - M8 x 65 : 1.25 - 10.9	1	-
13	2704.5471	Spline Screw - M8 x 45 : 1.25 - 10.9	4	-
14	2704.5481	Hex Screw with washer - M8 x 35 : 1.25 - 10.9	4	-
15	2704.5691	Spline Flange bolt - M8 x 30 : 1.25 - 8.8	2	-

**COMPATIBLE COMPRESSORS / COMPRESSEURS RECOMMANDÉS / EMPFOHLENE KOMPRESSOREN
RACCOMANDATO COMPRESSORI / RECOMENDADAS COMPRESORES**

SELTEC	TM-13 HS	TM15-HS	TM16-HS
Comp No	0381.5622	0381.5632	0381.5602
Valeo No.	-	-	-
Mounting	Ear	Ear	Ear
Rotor	6PV	6PV	6PV
GL	42.99	42.99	42.99
Armature	SL	SL	SL
Diameter	123	123	123
Voltage	12	12	12
Orientation	H	H	H
Fitting	3/4 x 7/8	3/4 x 7/8	3/4 x 7/8
Manifold	Bolt	Bolt	Bolt

QUE	QP13-HD	QP15-HD	QP16-HD
Comp No	0391.5622	0391.5632	0391.5602
Que No.	-	-	-
Mounting	Ear	Ear	Ear
Rotor	6PV	6PV	6PV
GL	42.99	42.99	42.99
Armature	SL	SL	SL
Diameter	123	123	123
Voltage	12	12	12
Orientation	H	H	H
Fitting	3/4 x 7/8	3/4 x 7/8	3/4 x 7/8
Manifold	Bolt	Bolt	Bolt

SANDEN	-	-	-
Comp No	-	-	-
Sanden No.	-	-	-
Mounting	-	-	-
Rotor	-	-	-
GL	-	-	-
Armature	-	-	-
Diameter	-	-	-
Voltage	-	-	-
Orientation	-	-	-
Fitting	-	-	-

NOTES

STANDARD FASTENER TORQUE VALUES

In the absence of specific torque values detailed in this fitting instruction manual, the following chart can be used as a guide to the maximum safe torque for specific size and grade of fastener.

COUPLES DE SERRAGE DES FIXATIONS STANDARDS

Si des chiffres de serrage au couple particuliers ne sont pas indiqués dans cette notice de montage, se référer au tableau suivant qui servira de guide pour le couple de sécurité maximum correspondant à une taille et un grade spécifiques de fixation.

ANZIEHMOMENTE FÜR STANDARDBEFESTIGUNGSMITTEL





Falls in dieser Einbauanleitung keine speziellen Anziehmomente angegeben sind, kann die folgende Tabelle als Richtlinie für das maximale sichere Anziehmoment für eine spezifische Größe oder Qualität von Befestigungsmitteln dienen.

VALORI STANDARD DI SERRAGGIO PER DISPOSITIVI DI FISSAGGIO

In assenza di valori specifici di coppia nel presente manuale di istruzioni, si può utilizzare la seguente tabella come guida per conoscere la coppia massima sicura in base a dimensioni e grado del dispositivo di fissaggio.

VALORES ESTÁNDAR DE LOS PARES DE APRIETE Y FIJACIÓN

En ausencia de valores para los pares de apriete específicos detallados en este manual de instrucciones de montaje, se puede utilizar la siguiente tabla como guía para consultar el máximo par de torsión seguro para un tamaño concreto y su grado de fijación.

STRENGTH								
	Max Torque		Max Torque		Max Torque		Max Torque	
Dia / Pitch	lb.ft	Nm	lb.ft	Nm	lb.ft	Nm	lb.ft	Nm
M5 x 0.80	2	3	4.5	6	6.5	9	7.5	10
M6 x 1.00	4	5.5	7.5	10	11	15	13	18
M8 x 1.25	10	13	18	25	26	35	33	45
M10 x 1.25	20	27	39	53	57	78	66	90
M10 x 1.50	18	25	37	50	55	73	63	86
M12 x 1.75	33	45	63	85	97	130	111	150
M14 x 2.00	55	75	103	140	151	205	177	240
M16 x 2.00	85	115	159	215	232	315	273	370

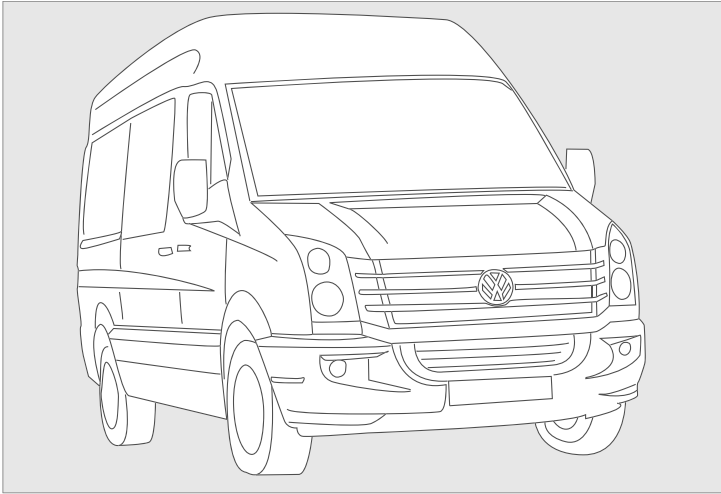

VEHICLE DETAILS

Manufacturer	Volkswagen
Make	Crafter
Model	CR30 / CR35 / CR39 / CR50
Engine	109PS / 136PS / 163PS ~ 2.0L (1968CC)
Engine Details	CKTB/CKTC/CKUC/CKUB~ Euro 5 / 6 / EEV
Year	10.2010>
Chassis Nos.	N/A
LHD	YES
RHD	YES
PAS	YES
A/C	YES / NO
Voltage	12v

KIT DETAILS

Kit Part No.	0500.7602
Description	Standard Kit
Compressor RPM	4375 @ Max Engine Power Output
Fitting Time	60 Minutes
Suction Fitting	Straight
Discharge Fitting	Straight
Belt Type	6PK 1010 / 4PK 711
Belt Part No.	0820.7231 / 0820.5231
Compatible with:	BlueMotion / Stop/start

FOREWORD

The purpose of this manual is to facilitate the installation of a direct drive compressor. The information given is merely instructive, should any complications arise contact the Technical department. The manufacturer's warranty does not cover any problems caused by defective installation or alterations made unless authorised. The manufacturer shall not be responsible for any injury, damage or loss caused directly or indirectly as a result of using this manual or the information contained within it.

1 SAFETY MEASURES:

Before fitting the Compressor adapter drive kit, ensure the following for damage:

- a Inner and outer trim and body work
- b Engine idle pace
- c Check all the vehicle functions

Check list:

- a Ensure that the right kit has been selected
- b Before installing, check that all the correct pieces are present; also ensure that there are no missing or broken pieces
- c When fitting, make sure the vehicle is properly protected against damage.

Installation apparatus

- a Calibrated torque wrench
- b Hand service tools
- c Protective covers and shields

2 PRECAUTIONS

- a Detach the battery negative lead.
- b Torque all bolts where stated using a calibrated torque wrench.
- c Take extreme care with moving parts.
- d Remove the vehicle's ignition key and keep it with you.
- e Wear safeguards and make sure that liquid refrigerant never touches your skin

Caution: Measures must be followed accurately to steer clear of the possibility of damage to individuals

Warning: This calls awareness to actions which must be pursued to avoid damage to the components.

NB: This calls awareness to make the job easier or gives useful information.

PRE INSTALLATION

N.B Prior to commencing work, please examine the instructions with care. The alphabetical symbols on the diagram relate to written instructions, numerical symbols relate to the parts listing..

Dismantle the following:

1. Cut the fan cowl along the original marked line (A) as shown - Fig 1
2. Remove and discard the original stretch belt - Fig 1
3. Mark the direction of rotation of the original alternator belt (B) rotate the automatic tensioner (C) clockwise and insert a 4mm locking pin in position (D). Remove and retain the original belt (B) - Fig 2

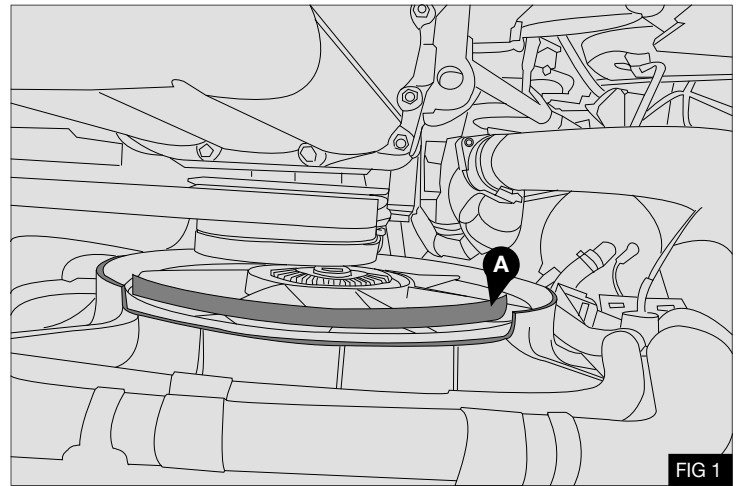

FIG 1

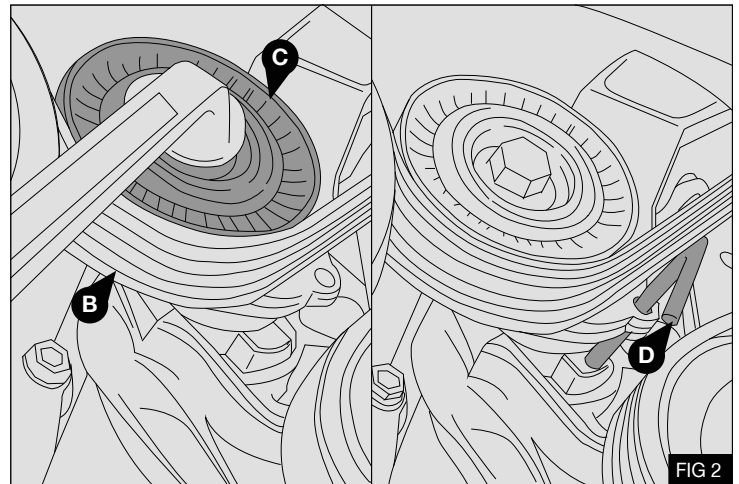

FIG 2

CRANKSHAFT PULLEY INSTALLATION

1. Remove and discard the 4x original crank pulley securing bolts (E) - Fig 3
2. **Note:** The crank pulley does not have an equally spaced bolt pattern, it is recommended that the following procedure is followed to ease installation – Remove the original crank pulley (F) and assemble on a bench together with the auxiliary pulley spacer (3) and the auxiliary pulley (2). Align the hole patterns and then mark the 2x pulleys and spacer with a suitable mark (X) to denote the correct alignment to each other - Fig 4

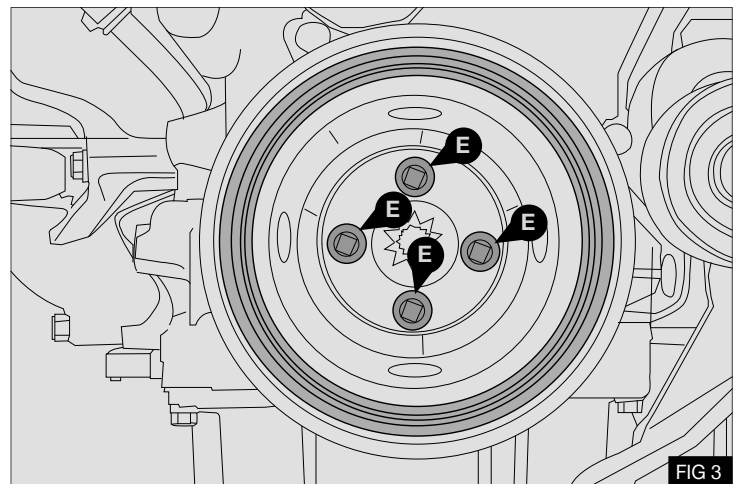

FIG 3

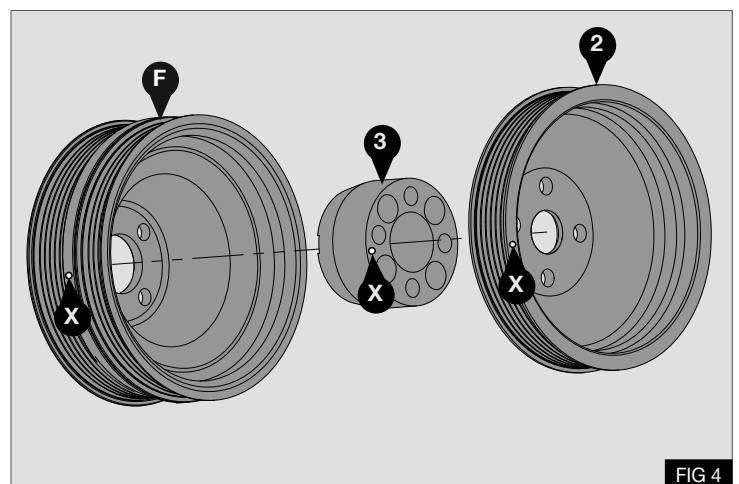
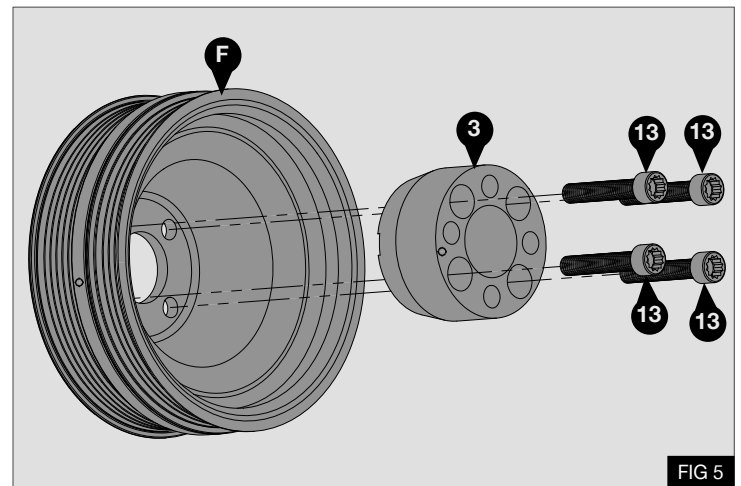
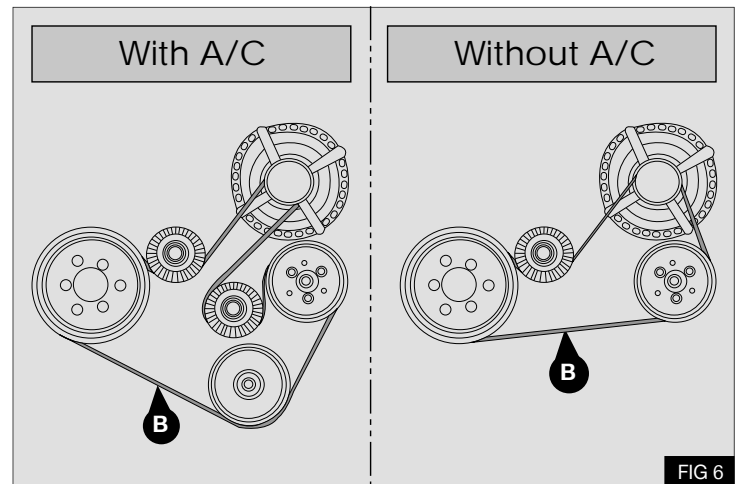

FIG 4

3. Align the crank pulley (F) with the auxiliary pulley spacer (3). Secure using 4 x M8 x 45 spline screws (13). Torque screws (13) diagonally to 23 Nm + 90° using a calibrated torque wrench - Fig 5



4. Refit the original drive belt (B) in the original direction of rotation - Fig 6



5. Remove the original bolts (G) securing the viscous fan bracket (H). Place the supplied stretch belt (6) over the back of the fan bracket (H) and onto the fan pulley. Torque bolts (G) to 50 Nm + 90° using a calibrated torque wrench - Fig 7

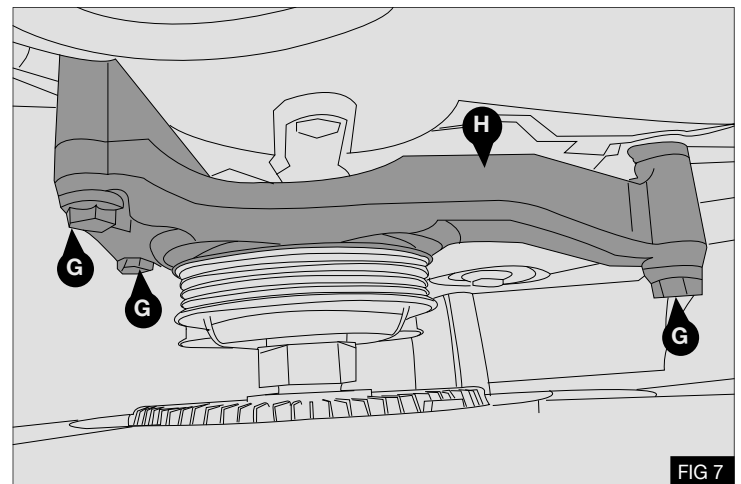

6. Install the supplied stretch belt (6) using a suitable tool (J) - Fig 8

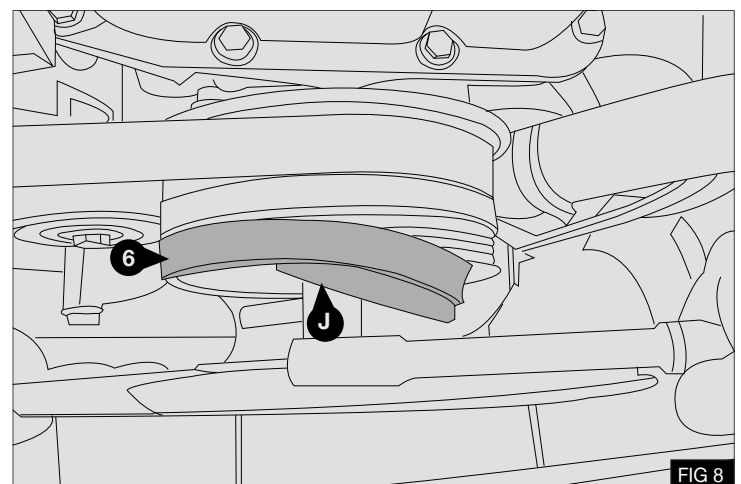

7. Align the auxiliary crank pulley (2) with the auxiliary pulley spacer (3). Secure using 4 x M8 x 35 bolts (14). Torque screws (14) diagonally to 23 Nm + 90° using a calibrated torque wrench - Fig 9
8. Install the supplied pulley grommet (7) into auxiliary pulley (2) - Fig 9

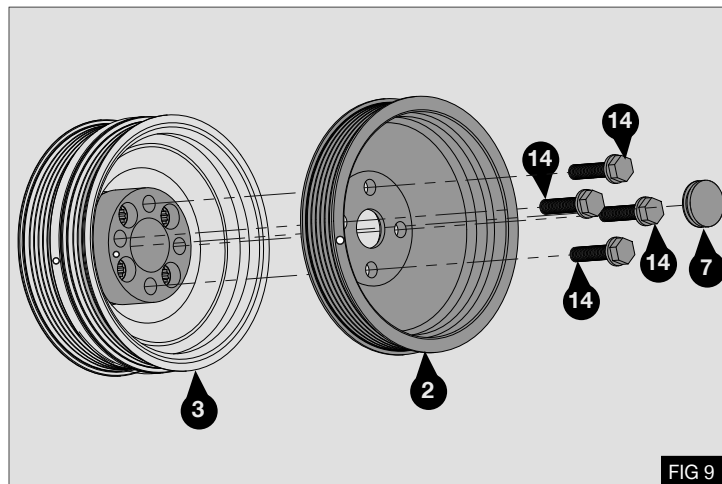

MOUNT BRACKET INSTALLATION

Note: Please refrain from using “Loctite” unless otherwise notified

IMPORTANT : Spacer shim (8) must be installed between the bracket (1) and the engine on single / mono turbo engines only.

1. If you are installing the mount bracket to twin / Bi turbo engines spacer shim (8) must be discarded - Fig 10
2. Install the mount bracket (1) with spacer (8) (If required) using bolts 2x (9), (10) and (12) Tighten bolts (9), (10) and (12) hand tight (10Nm) - Fig 10
3. Torque the front bolt (9) (arrowed) first to 40Nm + 90° - Fig 10
4. Torque the remaining bolts (9) and (10) to 40Nm + 90°. Torque bolt (12) to 23Nm + 90° - Fig 11

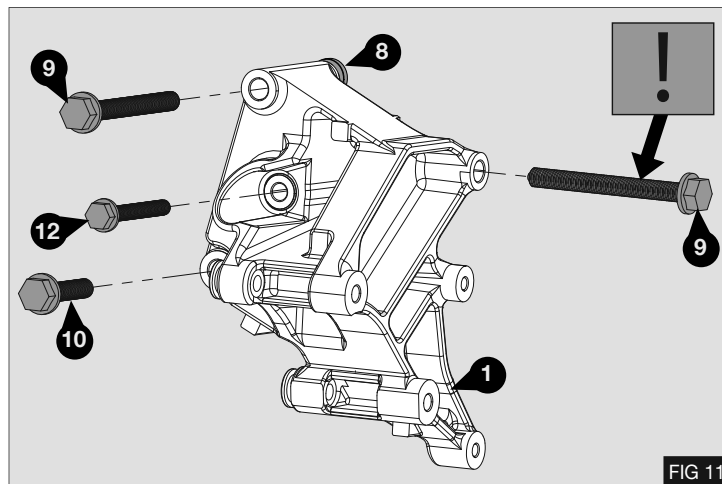
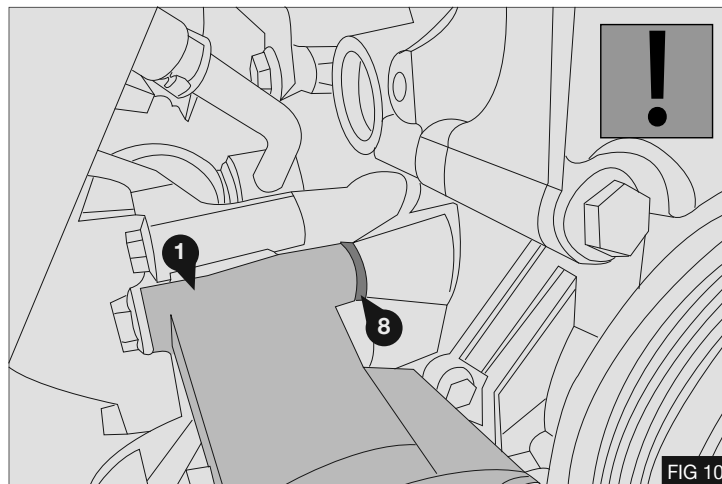

COMPRESSOR INSTALLATION

1. Install the compressor to the mount bracket (1) using 4 x M10 x 30 bolts (11) - Fig 12

Note: Tighten front 2 bolts first.

2. Torque bolts (11) to 20Nm +45° - Fig 12

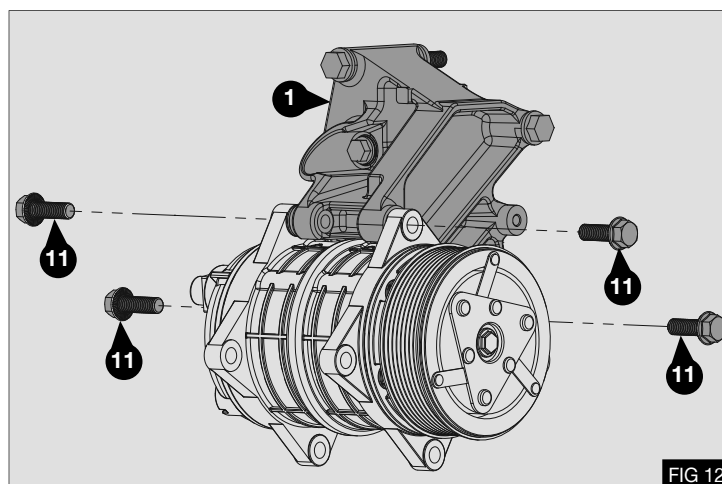

TENSIONER INSTALLATION

1. Install the tensioner (4) to the mount bracket (1) using 2x M8 x 30 bolts (15) - Fig 13
2. Torque bolts (15) to 20Nm + 45° - Fig 13

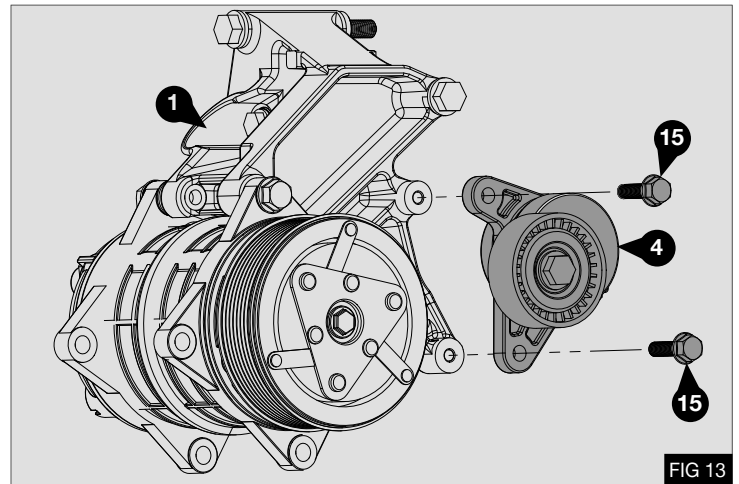

DRIVE BELT

1. Install the drive belt as shown opposite – Fig 14

- A. Crankshaft pulley
- B. Tensioner
- C. Compressor

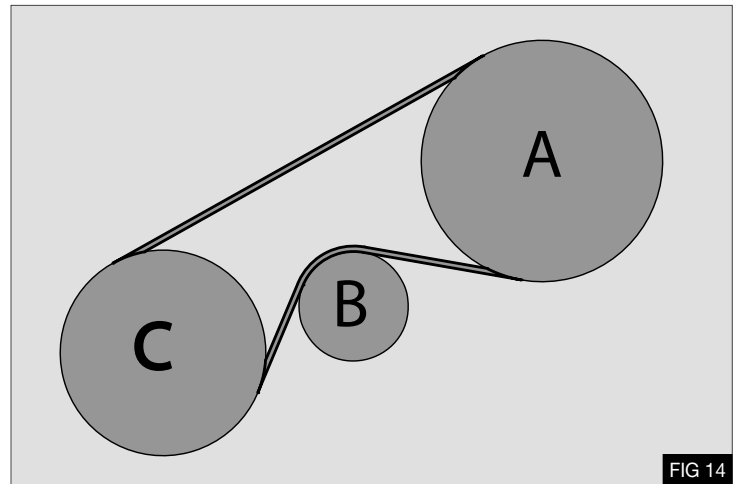

Place the belt in the correct groove of the compressor – Fig 15

⁽¹⁾6PK clutch

⁽²⁾Model Specific

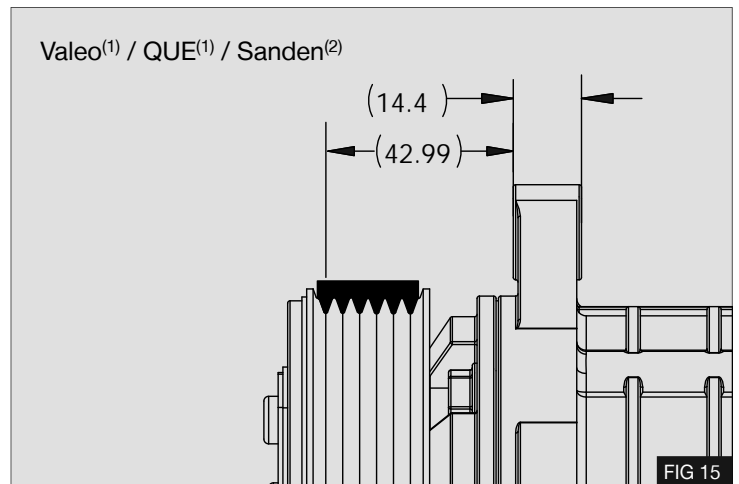

1. Valeo⁽³⁾ / QUE⁽³⁾ / Sanden⁽²⁾ compressors – Belt is installed leaving one spare groove at the front of the compressor pulley - Fig 16

⁽²⁾Model Specific

⁽³⁾8PK clutch

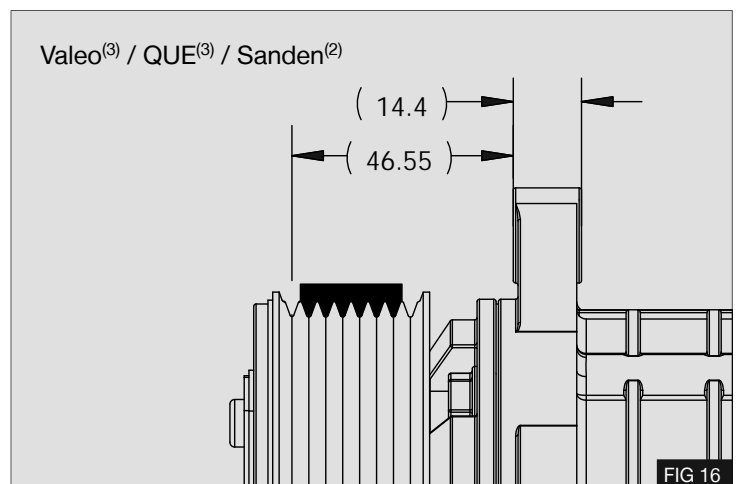

2. Delphi / Sanden⁽²⁾ compressors - Belt is installed leaving 2 spare grooves at the front of the compressor pulley - Fig 17

⁽²⁾Model Specific

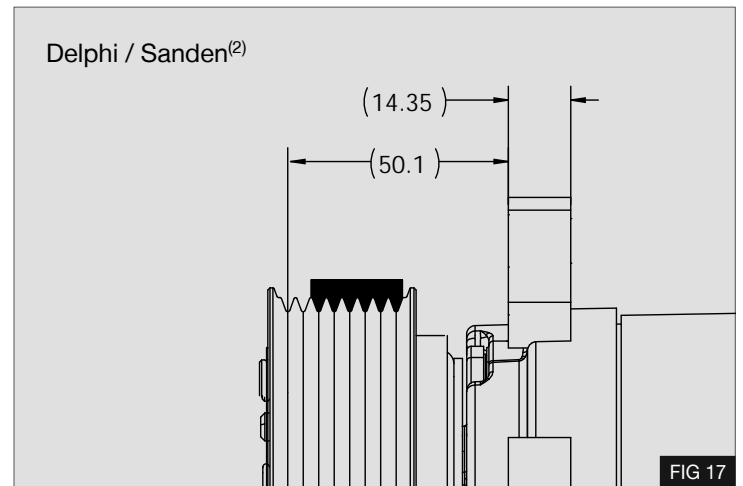

FINISH

1. Run the engine with the compressor clutch engaged for five minutes, Check all components.
2. Install the supplied belt label in the engine bay.

(EN)

Techni focuses on constant upgrading of its products. The Manufacturer reserves the right to modify the models and components described in the present publication at any time for technical or commercial reasons and without prior notice. For further information, contact Techni technical services.

(DE)

Techni ist stets bestrebt die eigenen Produkte zu verbessern. Die Herstellerfirma behält sich das Recht vor, aus technischen oder Verkaufsgründen, zu jeder Zeit und ohne vorherige Ankündigung, Abänderungen an den Modellen und den in dieser Veröffentlichung beschriebenen Einbauteile vorzunehmen. Für weitere Informationen bitten wir Sie, sich an unseren Techni Kundendienst zu wenden.

(FR)

Techni vise à une amélioration constante des ces produits. La maison se réserve le droit d'apporter, à tout moment et sans préavis, des modifications aux modèles et aux composants décrits dans cette publication pour des raisons d'ordre technique ou commerciale. Pour d'ultérieures informations s'adresser au service d'assistance Techni.

(IT)

Techni mira ad un costante miglioramento dei propri prodotti. La Casa si riserva il diritto di apportare in qualunque momento e senza preavviso modifiche ai modelli e ai componenti descritti in questa pubblicazione per ragioni di natura tecnica o commerciale. Per ulteriori informazioni rivolgersi al servizio assistenza Techni.

(ES)

Techni aspira a un constante mejoramiento de su producción. La Fábrica se reserva el derecho de aportar en cualquier momento y sin preaviso modificaciones a los modelos y los componentes descritos en esta publicación por razones técnicas o comerciales. Para ulteriores informaciones dirigirse al servicio asistencia Techni.

VENDITA E SERVIZIO
VENTE ET SERVICE

SALE AND SERVICE
VERKAUF UND SERVICE



Sundorne Trade Park, Henley Way,
Shrewsbury, United Kingdom, SY1 4NS
Telephone (+44) (0) 1743 443176
Fax (+44) (0) 1743 443113
Email: sales@techni.co.uk